

4

3

2

1

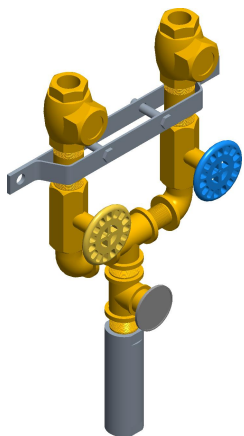

B

B

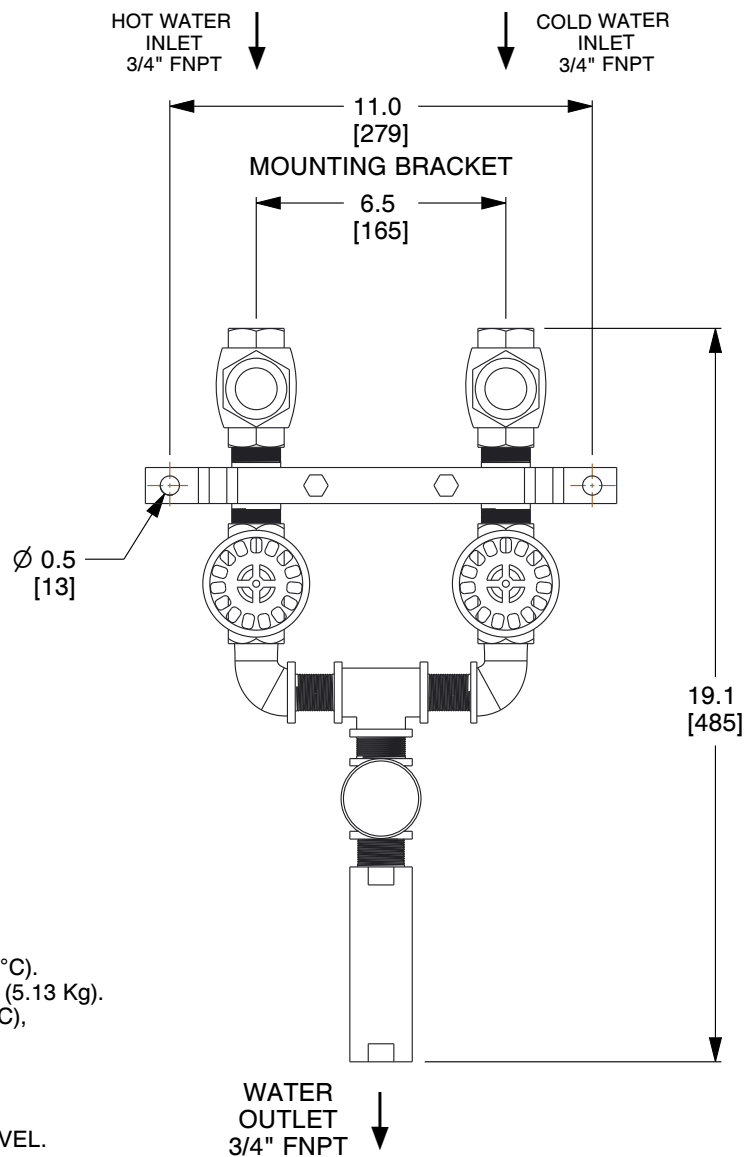
**NOTES:**

1. MAXIMUM WATER PRESSURE: 150 PSIG (10.3 BAR).
2. MAXIMUM WATER INLET TEMPERATURE: 200°F (93.3°C).
3. APPROXIMATE WEIGHT (W/O HOSE & GUN): 11.3 Lbs (5.13 Kg).
4. AVAILABLE SHUT-OFF TEMPERATURES: 125°F (51.6°C), 135°F (57.2°C), 150°F (65.6°C).

SIZES AND PIPE CONNECTIONS:

1. MIXING STATION: 3/4" NPT INLETS AND OUTLET.
2. HOSE: 3/4" NPT (MALE) SWIVEL x 1/2" NPT (MALE) SWIVEL.
3. GUN: ACCEPTS 1/2" MALE NPT.

A

A

COMPONENT	HOT & COLD WATER MIXING STATION
------------------	--



ThermOmegaTech, Inc.
353 Ivyland Road
Warminster, PA 18974-2205, USA
Ph: 215-798-5978

This file and any associated information and specifications are provided for reference and evaluation purposes only, and is subject to change without notice. ThermOmegaTech makes no representations, warranties or guarantees as to the appropriateness, accuracy, completeness, or suitability for any purpose, of the file, information or specifications. You are solely responsible for the use of the file, information or specifications.

This drawing is the property of ThermOmegaTech. It contains confidential, proprietary information that is ThermOmegaTech property. Do not disclose to or duplicate for others except as authorized by ThermOmegaTech.

SCALE

NTS

377-610030-XXX

HCX with SmartFlow, Brass construction

UNIT

INCH [MM]

SHEET

1 of 1

4

3

2

1