

4

3

2

1

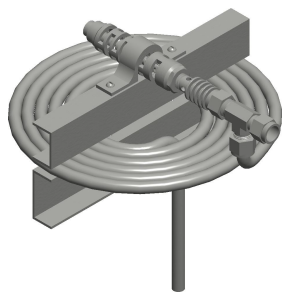

ITEM	DESCRIPTION	MATERIAL
1	TV/SC-A	SEE CATALOG PAGE
2	STEAM COIL	300 Series SS
3	MOUNTING BRACKET	300 Series SS
4	BULKHEAD FITTING	ACETAL COPOLYMER
5	TV/HAT	SEE CATALOG PAGE

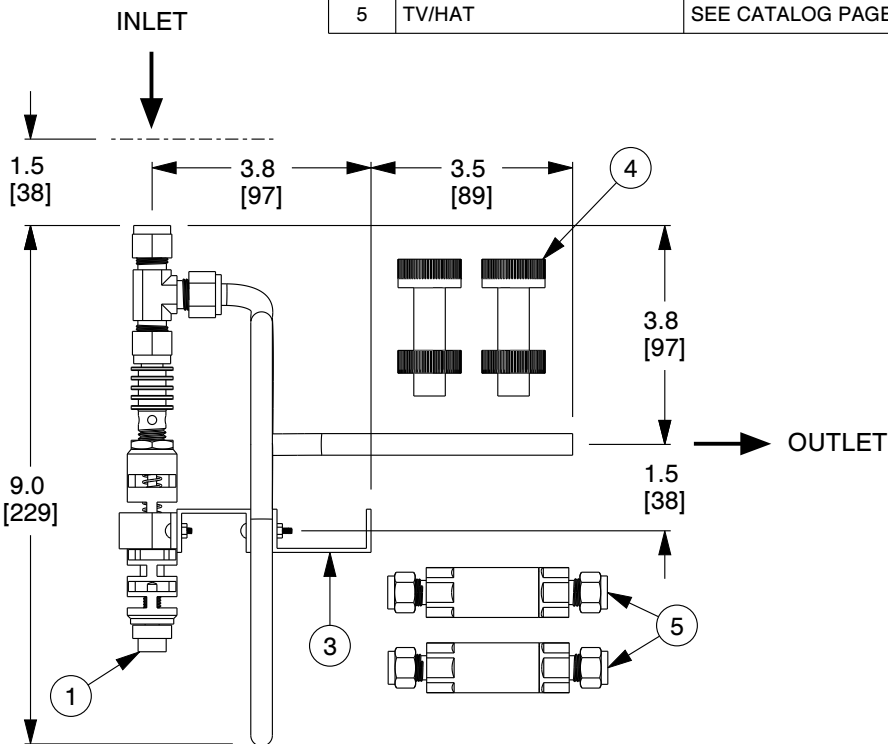
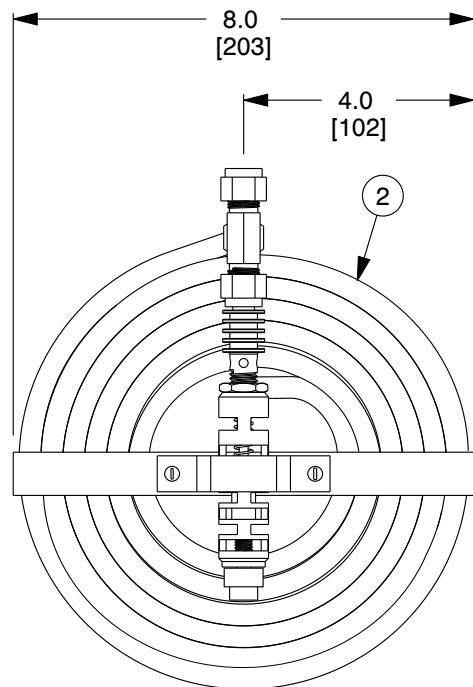
**NOTES:**

1. Cv: 0.5.
2. TUBE OD: 3/8".
3. MAXIMUM PRESSURE: 200 PSIG (13.8 BAR).
4. MAXIMUM TEMPERATURE: 250°F (121°C).
5. FULL OPEN TEMPERATURES "XXX" AVAILABLE: 35°F, 40°F, 50°F, 55°F, 60°F, 65°F, 75°F, 85°F, 90°F, 95°F, 100°F, 105°F, 110°F, 125°F, 130°F, 140°F, 150°F, 155°F, 160°F, 170°F, 180°F, 190°F AND 200°F.  
A. CLOSING TEMPERATURE IS TYPICALLY 10°F ABOVE OPENING TEMPERATURE.
6. A #20 MESH STRAINER IS RECOMMENDED FOR USE WITH ALL PORT SIZES.
7. REFER TO INSTALLATION AND MAINTENANCE INSTRUCTIONS FOR MOUNTING DIMENSIONS.

COMPONENT	INSTRUMENT TEMPERATURE CONTROL HEATER ASSEMBLY
-----------	--



ThermOmegaTech, Inc.  
353 Ivyland Road  
Warminster, PA 18974-2205, USA  
Ph: 215-798-5978

This file and any associated information and specifications are provided for reference and evaluation purposes only, and is subject to change without notice. ThermOmegaTech makes no representations, warranties or guarantees as to the appropriateness, accuracy, completeness, or suitability for any purpose, of the file, information or specifications. You are solely responsible for the use of the file, information or specifications.

This drawing is the property of ThermOmegaTech. It contains confidential, proprietary information that is ThermOmegaTech property. Do not disclose to or duplicate for others except as authorized by ThermOmegaTech.

SCALE

NTS

753-000000-XXX

3/8" ITC ASSEMBLY

UNIT

INCH [MM]

SHEET

1 of 1

4

3

2

1