

ITEM	DESCRIPTION	MATERIAL
1	VALVE BODY	300 series SS
2	VALVE PLUG	300 series SS
3	SPRING	300 series SS
4	CARRIER	300 series SS
5	THERMAL ACTUATOR	300 series SS

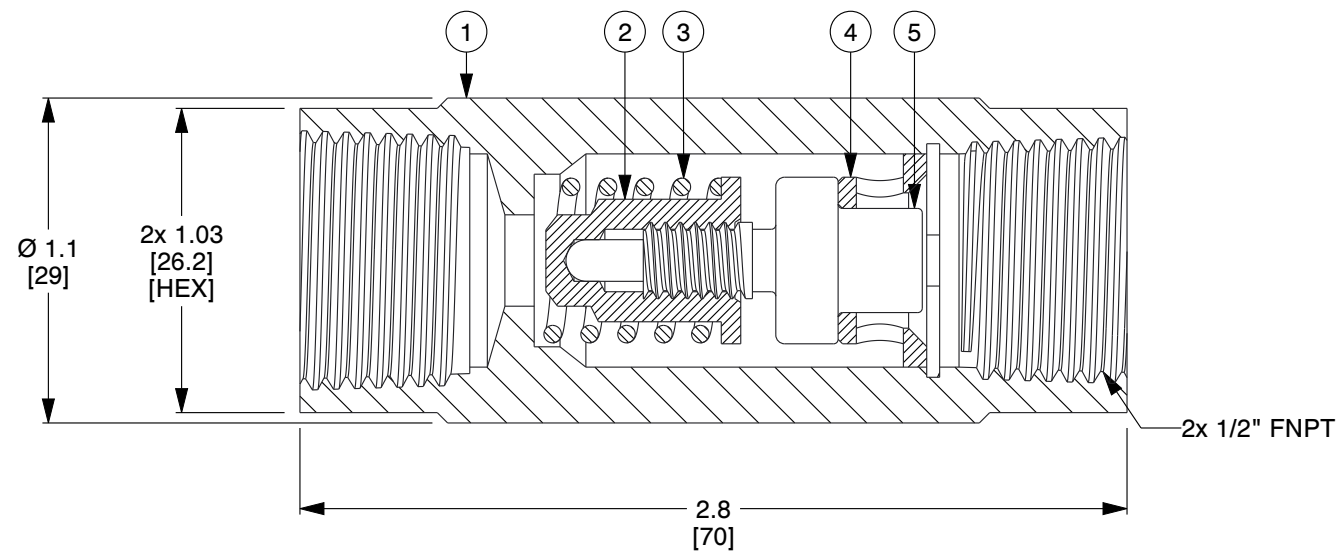

- NOTES:**
1. Cv: OPEN: 1.3, CLOSED: 0.2, DESIGN: 0.60.
 2. WEIGHT: 0.5 Lbs (0.2 Kg).
 3. MAXIMUM WORKING PRESSURE: 200 PSIG (14 BAR).
 4. MAXIMUM WORKING TEMPERATURE: 250°F (121°C).
 5. NSF-61 CERTIFIED FOR USE IN ALL DOMESTIC WATER SYSTEMS.

COMPONENT	CircuitSolver (CS)
-----------	--------------------

ThermOmegaTech
 ThermOmegaTech, Inc.
 353 Ivyland Road
 Warminster, PA 18974-2205, USA
 Ph: 215-798-5978

This file and any associated information and specifications are provided for reference and evaluation purposes only, and is subject to change without notice. ThermOmegaTech makes no representations, warranties or guarantees as to the appropriateness, accuracy, completeness, or suitability for any purpose, of the file, information or specifications. You are solely responsible for the use of the file, information or specifications.

This drawing is the property of ThermOmegaTech. It contains confidential, proprietary information that is ThermOmegaTech property. Do not disclose to or duplicate for others except as authorized by ThermOmegaTech.

SCALE	NTS
-------	-----

CS-1/2-XXX
 1/2"- CS

UNIT	INCH [MM]
SHEET	1 of 1